



INSTALLATION INSTRUCTIONS

PART NUMBER: 6000772

VEHICLE MAKE: GM

MODEL: CORVETTE Z51 / WITH J55 BRAKE PACKAGE

YEARS: 2020-2024

PRODUCT: ES+ FRONT

REVISION: REVISION A

REVISION DATE: 11 MARCH, 2024

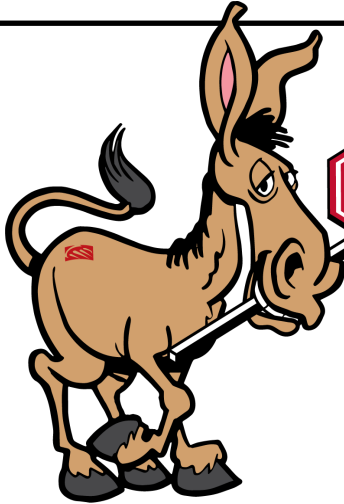

READ BEFORE CONTINUING!

Returns will not be accepted for ANY installed PART or ASSEMBLY. Use great care in preventing cosmetic damage when performing wheel fit check. If a product must be returned, please contact Baer customer service for an RMA number.

Notices – Read and Follow BEFORE ATTEMPTING INSTALLATION

- All installations require proper safety procedures and protective eyewear.
- All installations assume basic mechanical skill and a factory service manual for the vehicle on which the installation is to be performed.
- All references to the “left” side of the vehicle correlate to the driver’s side of the vehicle.
- Any installation requiring you to remove a wheel or gain access under the vehicle requires use of jack stands appropriate to the weight of the vehicle. In all cases, jack stands rated for a minimum of 2-tons is recommended.**
- A selection of hand tools sufficient to engage in the installation of these products is assumed and is the responsibility of the installer to have in his/her possession prior to beginning this installation. All installations, which require removal of hydraulic hoses and/or bleeding of the brakes, require appropriate fitting/line wrenches, safety catch can, and protective eyewear. Other than these items, if unique or special tools are required, they will be stated appropriately in the installation step.
- ALWAYS CONFIRM WHEEL FITMENT BEFORE BEGINNING INSTALLATION OF ANY BRAKE SYSTEM OR “UPSIZED” ROTOR UPGRADE!** In addition to checking wheel fitment of this system with the wheel fitment template (available online at www.Baer.com), always place the actual corner assembly or a combination of the caliper assembly on the rotor, and into the actual wheel with great care to prevent cosmetic damage. This procedure will reconfirm proper clearance between the caliper and the wheel before proceeding with the actual installation.
- Returns will **not** be accepted for systems that have been partially or completely installed. **Use extreme care when checking wheel fitment to prevent any cosmetic damage of brake components.** Wheel fitment should be verified before installation using a wheel fitment template supplied at www.Baer.com
- When installing new Baer rotors, be sure to follow the direction of rotation indicated on the rotor hat area with either an arrow, an “L” for left, or an “R” for right, or both. “L” always indicates the rotor for the driver side of US spec vehicles. Follow the rotor installation and rotation instructions included in the promo pack (P/N 6020101) included with your system when installing rotors. **Failure to properly install rotors will not allow for proper function of the brake system and will cause heat related fatigue and failure.**



- Note: Baer recommends taking photos of the brake system before disassembly and during each step of the disassembly process. Photos may allow technical support to better assist given any necessary troubleshooting.**
- If anything becomes unclear or any parts require force to install at any point during the installation, stop immediately and consult directly with Baer technical staff. Please have these instructions and the part number of the components that is/are proving difficult to install. Please provide technical staff with the make, model, and year (date of vehicle production is preferred) of your vehicle. Baer's technical staff is available by phone (602.233.1411) or email (ContactUs@Baer.com) from 8:30 AM - 5:00 PM MST (Mountain Standard Time) Monday - Friday (Arizona does not observe Daylight Savings Time).

REMOVAL OF EXISTING BRAKE ROTORS

1. Carefully lift the front end of the vehicle. Place appropriately rated jack stands under the vehicle in factory designated positions to support the front end of the vehicle as it is lifted from the ground.
2. Carefully remove the front wheels from the vehicle. Retain the factory lug nuts to re-secure the wheels to the hubs following installation.
3. Remove the two bolts securing the brake caliper to the knuckle with a 21mm socket (Figure 1). Retain this hardware as it will be used to reinstall the caliper following installation of the new ES+ rotors.
4. Carefully remove the caliper from the knuckle and retain, supported inside the vehicle wheel well (Figure 2, brake hose not shown in photo). **DO NOT allow the caliper to remain suspended in the air via the brake hose, this can damage the brake hose. Disconnecting the caliper from the brake hose is NOT necessary, doing so will require you to properly bleed the brake system per vehicle manufacturer specifications following reinstallation.**
5. Remove the flat head socket cap screw retaining the existing rotor to the hub (Figure 3). These will **not** be re-used to secure the new ES+ rotors to the hub.
6. Remove the existing brake rotor from the hub (Figure 4).
7. Inspect the hub mounting face for debris that could cause improper fitment of the new brake rotors. **Removal of the factory rotor dust shield is not required.**

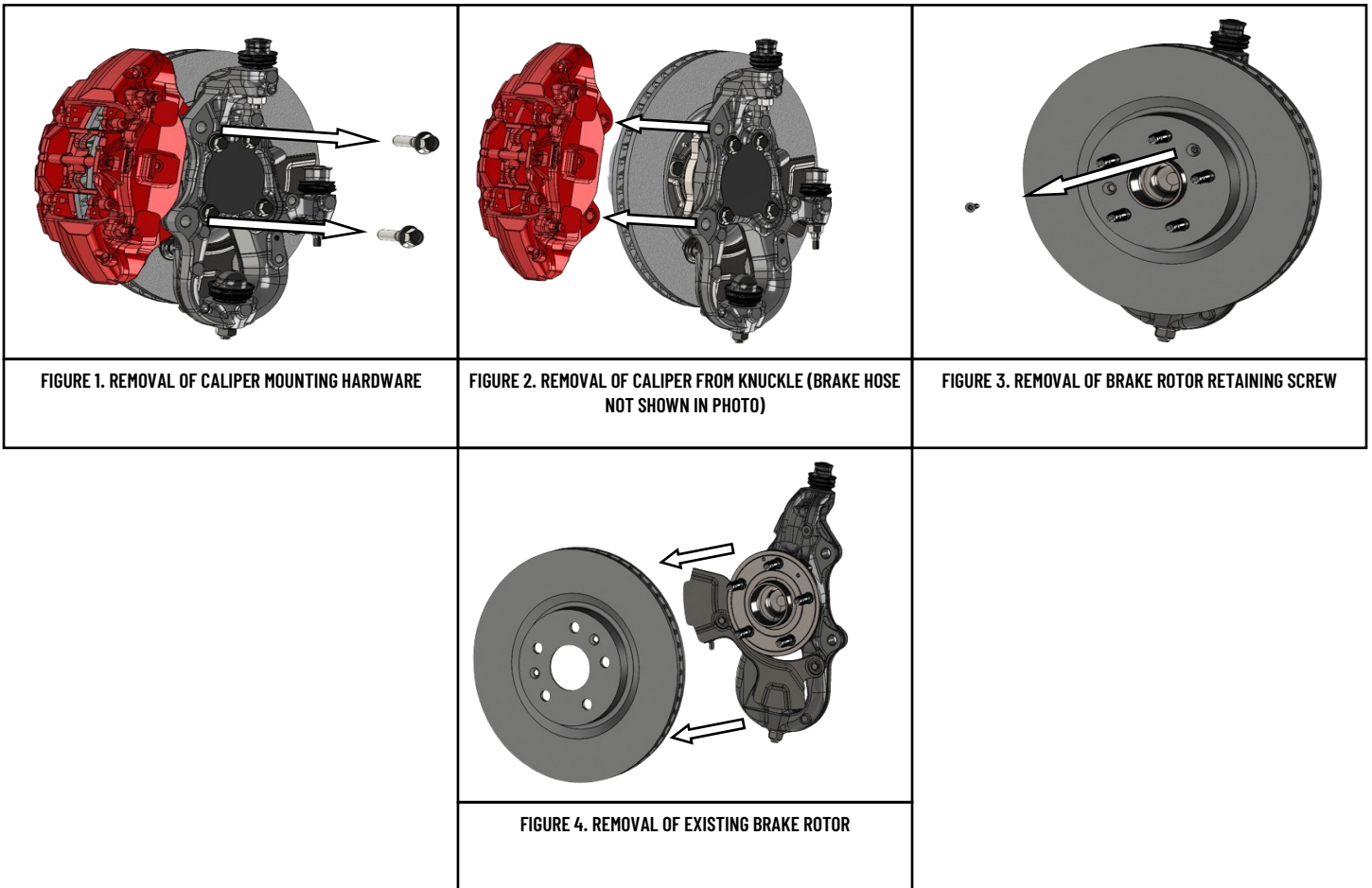

ES+ ROTOR INSTALLATION

1. Carefully install the correct side rotor, referring to the "Rotor Direction & Installation" instruction included in the supplied promotional packet.
2. Temporarily secure the rotor to the hub with three lug nuts and washers to prevent scratching the rotor hat face (Figure 5).

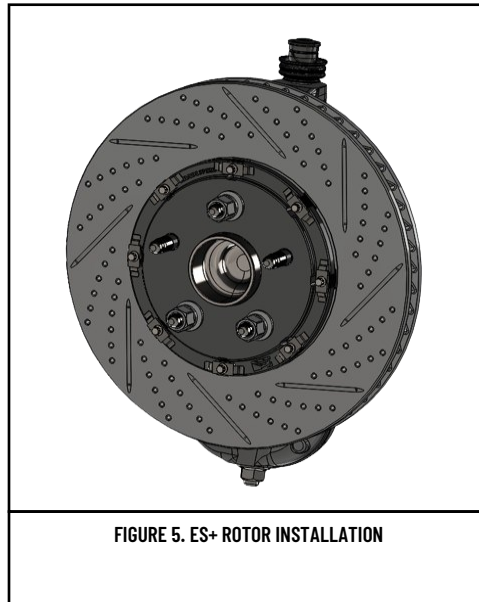
**CALIPER REINSTALLATION**

1. It is recommended to replace brake pads and rotors at the same time, now is the best time to replace the brake pads.
2. Carefully reinstall the caliper to the knuckle using the existing hardware removed in step 3 on the previous page (Figure 6).
3. Torque the caliper mounting hardware to the manufacturer specifications to secure the caliper to the knuckle.
4. Remove the previously installed lug nuts and washers from the rotor (Figure 7).
5. Perform the rotor seasoning and pad bedding procedures outlined within the supplied promotional packet.

